



Catalog No.	Type:
Job Name:	

99-LED Series

LED Decorative Frosted Glass Sconce

Features & Specifications:

The 9900 Series is a sconce fixture with frosted white lens for soft, glare free illumination. The glass sconce lens allows the lighting designer to produce a cost effective, yet elegantly styled look.

- ADA compliant
- White powder coated finish pan
- Standard with frosted glass diffuser
- Brushed Nickel accents
- Suitable for damp location
- Thermally Protected LED Array
- 8 Cree LEDs
- CRI of 80
- 3000 Color Temperature
- Constant current at 700 milliamps
- UL Class 2 driver >.90 power factor

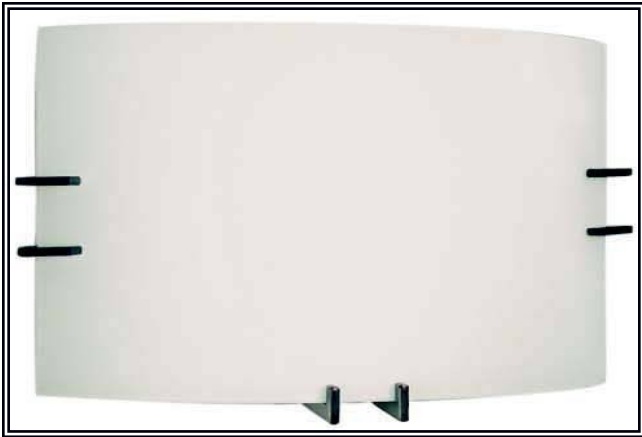

General Characteristics:

Lamp Type: LED Array
 Estimated Life: 50,000 Hours
 Standard Voltage: 120-277
 Wattage: 18 (22 Power Input)
 Ambient Temp.: -40°C– 40°C
 Mounting: Wall
 Additional Info.: UL Listed, ADA and Title 24 Compliant

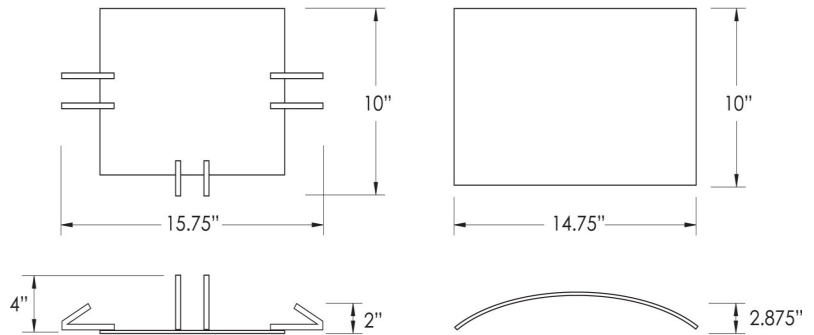

Catalog Ordering: Example: 99-L1700

99		
-----------	--	--

FAMILY TYPE	LAMPING	VOLTAGE
99	L1700 (1700 lm)	UNV (120-277 Volt)

Specifications and Dimensions Subject to change without notice
 FSC 12120 Altamar Place, Santa Fe Springs, CA 90670 Ph 562-906-2644 Fax 562-906-2649