



PAVER LIGHT

SL-44 / SL-44-66 / SL-44-69

TYPE

SPECIFICATIONS:

- FACE PLATE:** SL-44: Heavy duty .063 stamped aluminum. Powder coated black texture
SL-44-BRS: Heavy duty .040 stamped brass. Unfinished brass
- BACK BOX HOUSING:** Heavy duty .090 stamped aluminum. Powder coated high reflectance white
- LENS:** High impact white acrylic. (.175)
- LAMP SUPPLIED:** T-9 G4 10 watt Xenon bi-pin; 10,000 hours average rating
- LAMP OPTION:** T-9 G4 5 watt Xenon bi-pin
- SOCKET:** GU 5.3 bi-pin, ceramic contacts
- WIRING:** 8" 250c silicone lead wires
- CONNECTION:** Approved gel filled wire nuts (supplied by others)
- VEHICULAR PRESSURE RATING:** 8800 lbs
- FINISH:** Optional powder coat finishes & materials available
Acid treatment available for brass

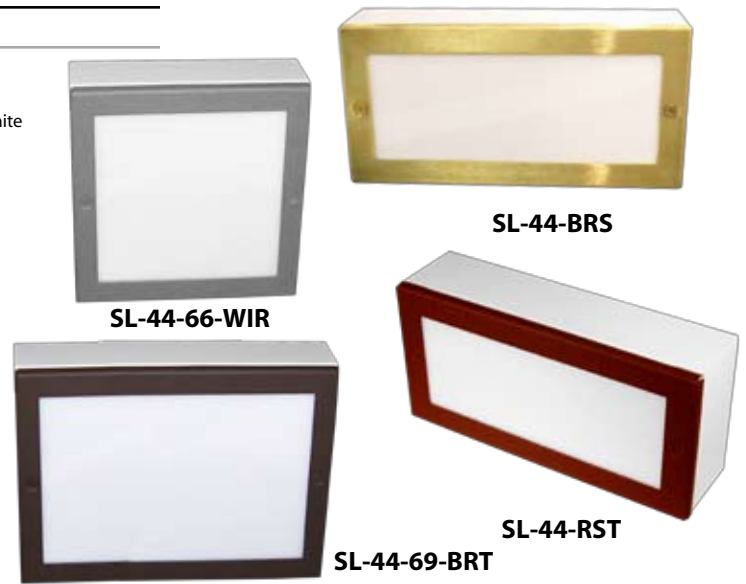

ORDERING INFORMATION

CATALOG NO.	DESCRIPTION	STANDARD FINISH	EST. SHIP. WEIGHT
SL-44-BLT	4" x 8" Brick Paver Light	Black texture	2.0 lbs
SL-44-66-BLT	6" x 6" Brick Paver Light	Black texture	2.0 lbs
SL-44-69-BLT	6" x 9" Brick Paver Light	Black texture	2.0 lbs
SL-44-BRS	4" x 8" Brick Paver Light	Unfinished brass	2.0 lbs
SL-44-66-BRS	6" x 6" Brick Paver Light	Unfinished brass	2.0 lbs
SL-44-69-BRS	6" x 9" Brick Paver Light	Unfinished brass	2.0 lbs
SL-44-COP	4" x 8" Brick Paver Light	Unfinished copper	2.0 lbs
SL-44-66-COP	6" x 6" Brick Paver Light	Unfinished copper	2.0 lbs
SL-44-69-COP	6" x 9" Brick Paver Light	Unfinished copper	2.0 lbs
SL-44-SS	4" x 8" Brick Paver Light	stainless steel	2.0 lbs
SL-44-66-SS	6" x 6" Brick Paver Light	stainless steel	2.0 lbs
SL-44-69-SS	6" x 9" Brick Paver Light	stainless steel	2.0 lbs



ACCESSORIES

CATALOG NO.	DESCRIPTION
FA-35-SL44 /-66 /-69 -WHITE	White (.175) High impact acrylic lens
FA-35-SL44 /-66 /-69 -BLUE	Blue (.125) High impact acrylic lens
FA-35-SL44 /-66 /-69 -GREEN	Green (.125) High impact acrylic lens
FA-35-SL44 /-66 /-69 -ORANGE	Orange (.125) High impact acrylic lens
FA-35-SL44 /-66 /-69 -RED	Red (.125) High impact acrylic lens

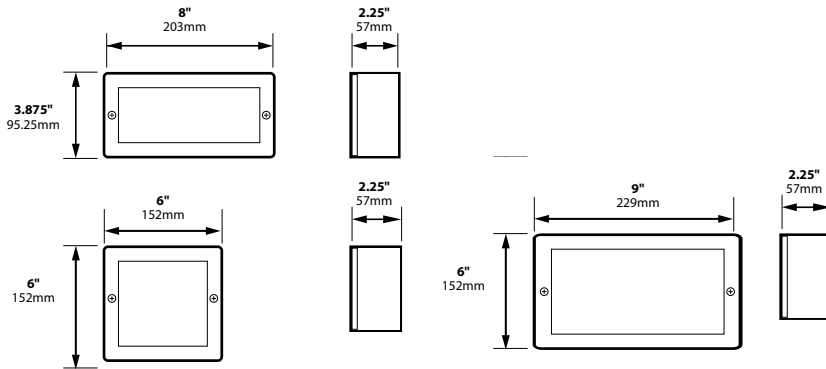
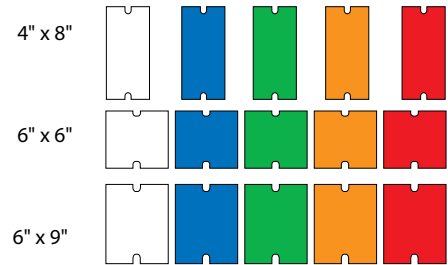

12v. fixtures: 25 foot 16/2 fixture lead wire available; add **-25F** to catalog number.
For use with Focus CPC or hub supplied by others.

JOB INFORMATION

Type: _____ Date: _____

Job Name: _____

Cat. No.: _____

Lamp(s): _____

Specifier: _____

Contractor: _____

Notes: _____

FOCUS INDUSTRIES® INC.
25301 COMMERCENTRE DRIVE
LAKE FOREST, CA 92630

www.focusindustries.com
sales@focusindustries.com
(949) 830-1350 • FAX (949) 830-3390

Powder Coat Finishes	Black Texture (Standard)	Antique Verde	Bronze Texture	Camel	White Texture	Hunter Texture	Rust	Weathered Iron	Weathered Brown	Stucco	Rubbed Verde	Chrome Powder	Terra Cotta	Acid Rust *	Acid Verde *
Ordering Code	-BLT	-ATV	-BRT	-CAM	-WTX	-HTX	-RST	-WIR	-WBR	-STU	-RBV	-CPR	-TRC	-B/CAR	-B/CAV

*For Brass or Copper Only



landscape • entertainment • architectural • hospitality • illumination

NEW PRODUCT eNEWS

www.focusindustries.com

SL-44 /SL-44-66/SL-44-69-BRS/-COP/-SS PAVER LIGHTS

SL-44

- T9 G4 10 watt Xenon Bi-pin
- 10,000 hours
- Multiple lens plate finish options



SL-44-RST



SL-44-66-WIR



SL-44-69-BRT



UNDER PRESSURE VEHICULAR PRESSURE RATING: 8800 lbs

Colored Lens Options Holiday Lighting Enhancements



Color is only visible when illuminated!