

PH Louvre

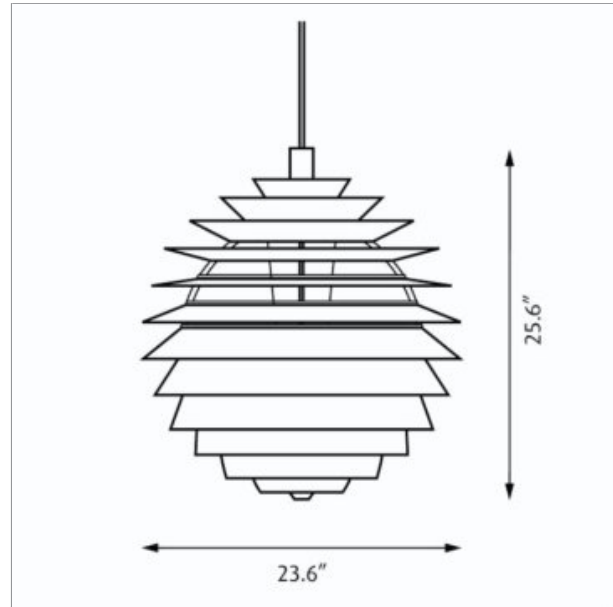

Design: Poul Henningsen

Concept: The fixture provides 100% glare-free light. The geometrical, spherical design is based on the principle of illuminating all surfaces at the same angle. This ensures uniform light around the fixture, illuminating both walls and ceiling. Matte painted undersurfaces and glossy top surfaces result in an attractive reflection of the diffused light, creating uniform light distribution around the fixture.

Finish: White, wet painted.

Material: Shades: Spun aluminum. Frame: High lustre chrome plated, extruded brass. Housing: High lustre chrome plated, spun aluminum.

Mounting: Suspension type: 1x stainless steel aircraft cable. Suspension length: 12'. Canopy: White. Cord type: 3-conductor, 18 AWG white PVC power cord. Cord length: 12'.

Weight: Max. 20 lbs.

Label: cULus, Dry location. IBEW.

Product code	Light source	Voltage	Finish
PHL-P	1/250W/MH/ED-28-0 mogul 1/400W/MH/ED-37 mogul 1/500W/PS-35/CL mogul	120/277V 120V	WHT

Specification notes

- a. MH variants provided with one remote mounted 120/277V F-can style ballast.
- b. Incandescent variants only available in 120V.
- c. 1/250W/MH light source must be open rated.

Info notes

- II. The comparable EU version has the following classification: Ingress Protection Code: IP20.

**louis
poulsen**