



# The right solution

**Philips Advance Centium® ballasts for 40W twin tube lamps** are the right solution when looking for a lot of light in a small package

When looking for a lot of light in a small convenient package the right solution is Philips Advance Centium® ballasts for 40W twin tube lamps. These instant start ballasts are available with IntelliVolt® technology as well as lamp End-Of-Life (EOL) protection circuitry in an industry standard small can.

Lightweight and compact these ballasts provide flexibility and design versatility making them ideal for use in various types of office applications in the commercial, retail, hospitality and healthcare markets. The instant start feature delivers independent lamp operation keeping the remaining lamps ON even when one lamp goes out.

These ballasts are compatible with the Philips Energy Advantage PLL 40/25W Lamp as well as the Sylvania 40/28W Dulux L Super Saver lamp.\*

\* Limitations apply cold starting; please consult Philips Lighting Electronics Product Management prior to using in these applications.

#### IntelliVolt® technology

- Enhances accuracy and ease of ordering while reducing stocking and SKU requirements

#### Improved electronic circuitry

- Delivers 7% energy savings over our dedicated voltage ballasts\*\*

#### Lamp End-Of-Life (EOL) protection circuitry

- Removes power to lamps upon lamp failure

#### Compact and lightweight housing measuring (9.5"L x 1.7" W x 1.18"H)

- Promotes enhanced versatility and design flexibility

\*\* Based on input watts of Philips Advance's ICN-2TTP40-SC (68 watts) and RCN-2TTP40-SC (72 watts)

No. of Lamps	Input Volts	Lamp Starting Method	Ballast Family	Catalog Number	Input Power ANSI (Watts)	Ballast Factor	Max. THD %	Line Current (Amps)	Min. Starting Temp. (°F /°C)	Dim.	Wiring Diag.
<b>FT40W/2G11/RS (40W) - PLL40W, F40BX, FT40DL/RS</b>											
1	120-277	IS	Centium	ICN-1TTP40-SC	39 - 38	0.90	10	0.33 - 0.14	0/-18	B	70*
				ICN-2TTP40-SC	41	1.00		0.35 - 0.15			
2	120-277	IS	Centium	ICN-2TTP40-SC	68 - 67	0.88	10	0.57 - 0.25	0/-18	B	71*
				ICN-3TTP40-SC	73 - 72	0.96		0.61 - 0.27			
3	120-277	IS	Centium	ICN-3TTP40-SC	99 - 97	0.88	10	0.83 - 0.35	0/-18	B	72
<b>FT40W/2G11/ES (PLL 40/25W)</b>											
1	120-277	IS	Centium	ICN-1TTP40-SC	33 - 32	0.90	10	0.28 - 0.12	0/-18	B	70*
				ICN-2TTP40-SC	35	1.00		0.29 - 0.13			
2	120-277	IS	Centium	ICN-2TTP40-SC	58 - 57	0.88	10	0.48 - 0.21	0/-18	B	71*
				ICN-3TTP40-SC	60	0.96		0.51 - 0.22			
3	120-277	IS	Centium	ICN-3TTP40-SC	82 - 80	0.88	10	0.67 - 0.29	0/-18	B	72

\* Insulate unused blue lead for 600V

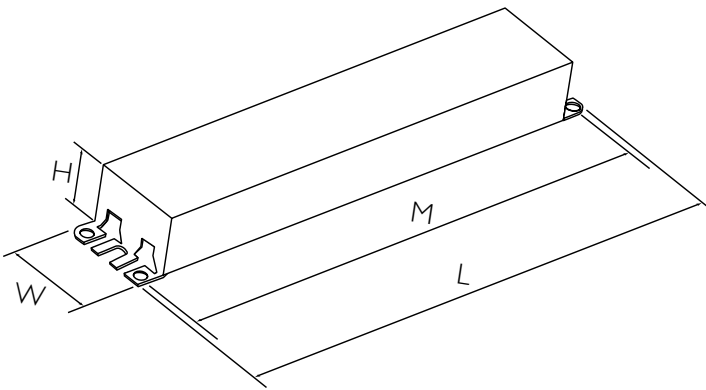

Fig. B

9.5" (L) x 1.7" (W) x 1.18" (H) x 8.9" (M)

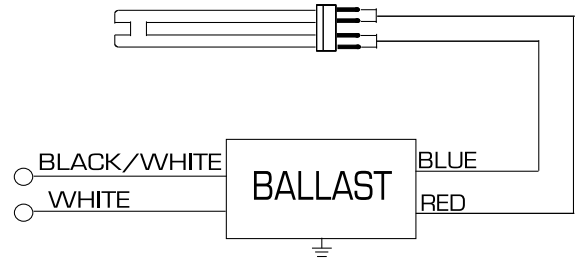

Fig. 70

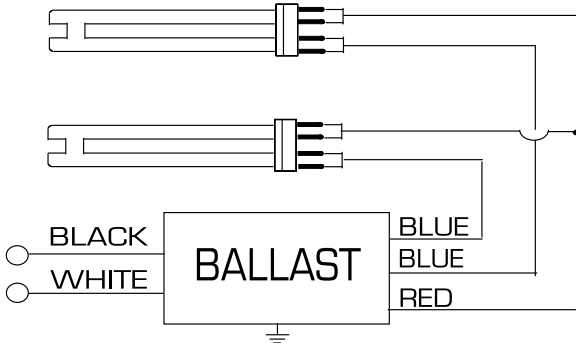

Fig. 71

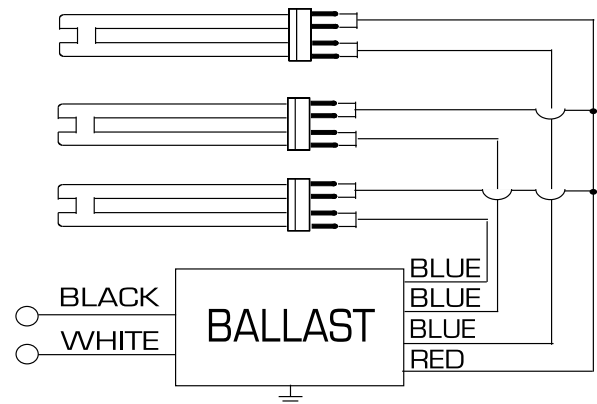

Fig. 72

# Ballast Specification for Centium Electronic Fluorescent

## Section I - Physical Characteristics

- 1.1 Ballast shall be physically interchangeable with standard electromagnetic or standard electronic ballasts, where applicable.
- 1.2 Ballast shall be provided with integral leads color-coded per ANSI C82.11.

## Section II - Performance Requirements

- 2.1 Ballast shall be Instant Start.
- 2.2 Ballast shall provide Independent Lamp Operation (ILO) for Instant Start ballasts allowing remaining lamp(s) to maintain full light output when one or more lamps fail.
- 2.3 Ballast shall provide lamp EOL protection circuit.
- 2.4 Ballast shall operate from 50/60 Hz input source of 120V through 277V with sustained variations of +/- 10% (voltage and frequency) with no damage to the ballast.
- 2.5 Ballast shall be high frequency electronic type and operate lamps at a frequency above 42 kHz to avoid interference with infrared devices and eliminate visible flicker.
- 2.6 Ballast shall have a Power Factor greater than 0.98 for primary lamp.
- 2.7 Ballast shall have a ballast factor of 0.88 for primary lamp applications.
- 2.8 Ballast shall provide for a Lamp Current Crest Factor of 1.7 or less in accordance with lamp manufacturer recommendations.
- 2.9 Ballast input current shall have Total Harmonic Distortion (THD) of less than 10% for Centium models when operated at normal line voltage with primary lamp.
- 2.10 Ballast shall have a Class A sound rating.
- 2.11 Ballast shall have a minimum starting temperature of -18°C (0°F) for Long Twin Tube lamps for primary lamp application.
- 2.12 Ballast shall tolerate sustained open circuit and short circuit output conditions without damage.

## Section III - Regulatory Requirements

- 3.1 Ballast shall not contain any Polychlorinated Biphenyl (PCB).
- 3.2 Ballast shall be Underwriters Laboratories (UL) listed, Class P and Canadian Standards Association (CSA) certified where applicable.
- 3.3 Ballast shall comply with ANSI C62.41 Category A for Transient protection.
- 3.4 Ballast shall comply with ANSI C82.11 where applicable.
- 3.5 Ballast shall comply with the requirements of the Federal Communications Commission (FCC) rules and regulations, Title 47 CFR part 18, Non-Consumer (Class A) for EMI/RFI (conducted and radiated).

## Section IV - Other

- 4.1 Ballast shall be manufactured in a factory certified to ISO 9002 Quality System Standards.
- 4.2 Ballast shall carry a \_\_\_\_\_ warranty from date of manufacture against defects in material or workmanship for operation at a maximum case temperature of \_\_\_\_\_  
(Go to our web site for up-to-date warranty information: [www.advancetransformer.com/warranty](http://www.advancetransformer.com/warranty)).
- 4.3 Manufacturer shall have a fifteen-year history of producing electronic ballasts for the North American market.
- 4.4 Ballast shall be Philips Advance part # \_\_\_\_\_ or approved equal.



©2008 Philips Lighting Electronics N.A.  
All rights reserved.

Form No. EL-2480-R01 | 1/08

Philips Lighting Electronics N.A.  
10275 W. Higgins Road  
Rosemont IL 60018  
Tel: 800-322-2086 Fax: 888-423-1882  
Customer Support/Technical Service: 800-372-3331  
OEM Support: 866-915-5886  
[www.philips.com/advance](http://www.philips.com/advance)