

FEATURES & SPECIFICATIONS

INTENDED USE

The **Alcon Lighting 14028 Edge Lit LED** direct luminaire offers abundant light and a modern slim design perfect for today's interior spaces, suited for recessed, suspended, and surface mount applications for offices, conference rooms, corridors, schools, labs, and public spaces.

DETAILS

W 23.8" x **L** 23.8" x **H** .6"

Construction: Aluminum Housing

Finish: White

Lens: Translucent White PMMA lens, Frosted

ADDITIONAL FEATURES

Voltage: 100-277 (50/60 Hz)

Wattage: 27W

Luminous Efficiency: 120 lms/w

Lumens: 3240 lms

Dimming: 0-10V 5%-100%

CRI: 80

Operating Temperature: 14-104°F (-10-40°C)

Life: L70 - 100,000 Hrs

Listing: IP40 Rated

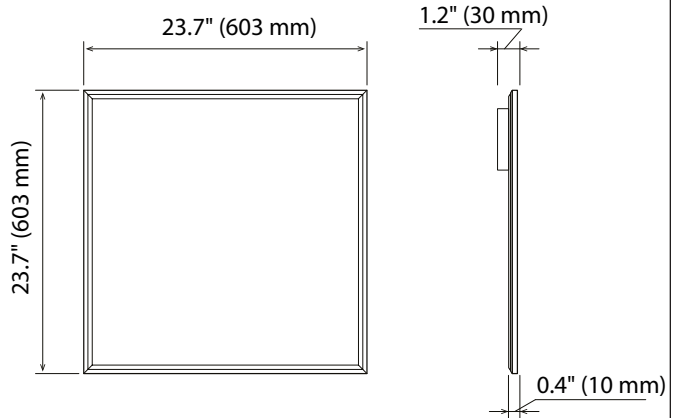

Alcon Lighting **14028 Edge Lit** Architectural LED 2x2 Flat Panel Recessed High Efficiency Direct Light Troffer

Ordering Information:

Example: (14028-50K-SM)

Model	Color Temp	Options
<input type="text" value="14028"/>	<input type="text" value="35K 3500K"/> <input type="text" value="40K 4000K"/> <input type="text" value="50K 5000K"/>	<input type="text" value="4C 4' Ceiling Hanging Set"/> <input type="text" value="6C 6' Ceiling Hanging Set"/> <input type="text" value="SM Surface Mount Frames"/> <input type="text" value="DF Drywall Flushmount Kit"/>