

SHOP NOW >

## FEATURES & SPECIFICATIONS

### INTENDED USE

The **Alcon Lighting 14075 Direct Lit Recessed LED** direct luminaire offers abundant light and a modern slim design perfect for today's interior spaces, suited for recessed, suspended, and surface mount applications for offices, conference rooms, corridors, schools, labs, and public spaces.

### DETAILS

**W** 23.8" x **L** 23.8" x **H** 2.8"

**Construction:** Aluminum Housing

**Finish:** White

**Continuous Run:** Up to 20 dimmable panels can be linked to each master panel

### ADDITIONAL FEATURES

**Voltage:** 100-277 (50/60 Hz)

**Luminous Efficiency:** 110 lms/w

**Dimming:** 0-10V 5%-100%

**CRI:** 80

**Operating Temperature:** 14-104°F (-10-40°C)

**Max Current:** 800 mA

**Life:** L70 - 100,000 Hrs

**Lens:** Translucent White PMMA lens, Frosted

**Listing:** IP40 Rated

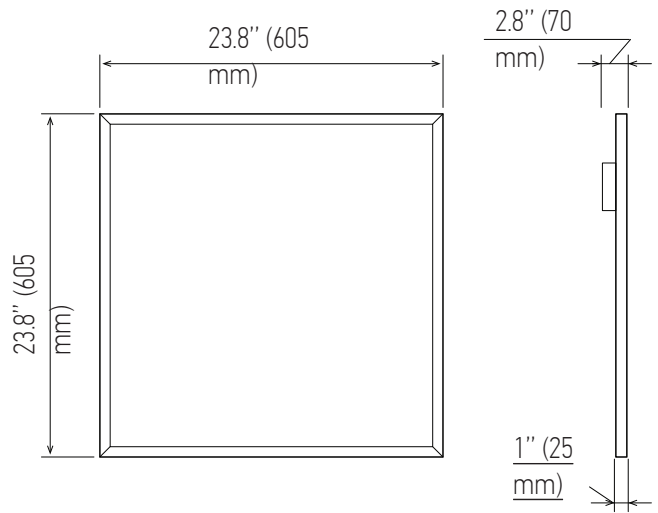

Alcon Lighting **14075 Direct Lit** Architectural LED 2x2 Recessed Flat Panel Direct Light Troffer

### Ordering Information:

Example: (14075-22-35)

Model	Wattage and Lumens	Color Temp
<b>14075</b>	<b>22</b> 22 watts, 2420 lms	<b>35</b> 3500K
	<b>27</b> 27 watts, 2970 lms	<b>40</b> 4000K
		<b>50</b> 5000K