

Project Name: _____ Type: _____ Quantity: _____

INTENDED USE

The Alcon Lighting 9160 Volterra Architectural LED Directional Up Light Fixtures features naturally etched finishes capable of withstanding the test of time. The Volterra Directional Uplight is ideal for architectural landscape lighting applications.

FEATURES

- Construction:** Cast Aluminum
- Wiring:** Pre-wired with 24" SPT-1 Cord
- Gasket:** Sealed with high grade weatherproof Silicone Gasket
- Socket:** Premium grade Porcelain socket with Nickel contacts and Teflon-jacketed wire leads
- Lens:** Tempered Glass Lens
- Voltage:** 12 Volts
- Wattage:** 6 Watts
- Lumens:** 400lms
- Life:** 50,000 Hours
- Beam Spread:** 30°
- Warranty:** 1 Year Carefree for Parts & Components
(Labor Not Included)
- Listings:** cETLus, RoHS

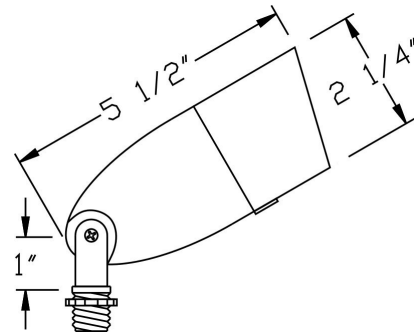

Alcon Lighting 9160 Volterra Architectural Landscape LED Low Voltage Directional Uplight Fixture



ORDERING INFORMATION Example: (9160-BR-30K)

Model	Finish	Color Temperature
9160	WH	30K
	White	3000K
	BK	47K
	Black	4700K
	BR	
	Bronze	