

Spotless Lens

Project _____

Type _____

Notes _____

PERFORMANCE PER LINEAR FOOT AT 3500K

NOMINAL LUMEN OUTPUT	INPUT WATTS*	EFFICACY	SHIELDING
400 lm/ft	4.02 W/ft	99 lm/W	SO
500 lm/ft	5.05 W/ft	99 lm/W	SO
750 lm/ft	7.57 W/ft	99 lm/W	SO
1000 lm/ft	9.9 W/ft	99 lm/W	SO
1000 lm/ft	9.9 W/ft	97 lm/W	L

Please consult factory for custom lumen output and wattage.

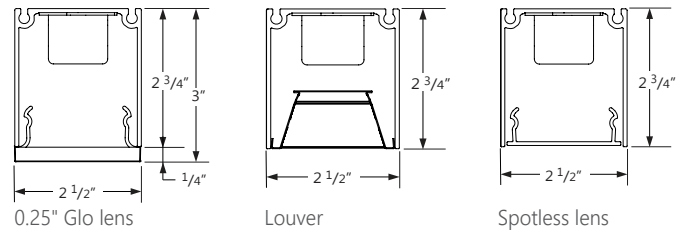
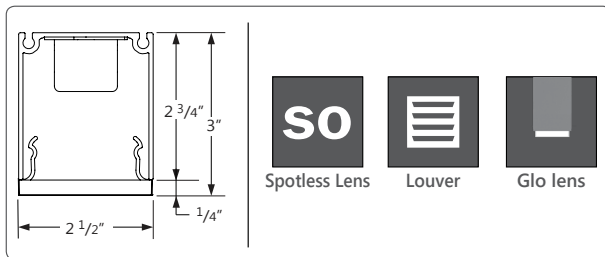

Ordering Guide

B2SQDLED		NOM. LUMENS/FT		CRI	COLOR TEMP.	SHIELDING	
PRODUCT ID	Surface LED	400	400 lm/ft - Minimum	80 80 CRI	27 2700 K	SO spotless Lens	
		1000	1000 lm/ft - Maximum*	90 90 CRI	30 3000 K	L louver ⁽¹⁾	
					35 3500 K	0.25G 0.25" Glo lens	
					40 4000 K		
Outputs between listed min and max are available. Consult factory for outputs outside of the listed range.						(1) Available in 3' and 4' combinations; otherwise consult factory.	

LENGTH	MR (OPTIONAL)	FINISH	VOLTAGE	DRIVER	CIRCUITS
2 2'	DMLED(#) downlight modle LED	AP aluminum paint	120 120 V	DP dimming (0-10V) 1%	1 1 circuit 2 2 circuits +E(#) emergency circuit ⁽⁴⁾ +NL(#) night light circuit ⁽⁴⁾ +GTD(#) generator transfer device ⁽⁴⁾ +M MR
3 3'		W white	277 277 V	LT Lutron ⁽²⁾	
4 4'		BLK black	347 347 V	BI bi-level dimming	
5 5'		C custom	UNV universal	O other ⁽³⁾	
6 6'					
8 8'					
12 12'					
S# system run					
Add 6" per lamp. Specify quantity. Separate circuits included				(2) Specify system (3) Please consult factory; see page 2	(4) Specify quantity

MOUNTING/SUSPENSION	BATTERY (OPTIONAL)	OTHER (OPTIONAL)	IC CONTROLS (OPTIONAL)	CUSTOM (OPTIONAL)
SB9 surface TB/TG 9/16 SB15 surface TB/TG 15/16 SBS surface screw slot t-bar S surface drywall ceiling SC surface solid ceiling	B# battery pack (integral)	F fuse	DS# daylight sensor OS# occupancy sensor DOS# daylight & occupancy sensor EN# Enlighted integral ⁽⁵⁾ ENR# Enlighted remote ⁽⁵⁾ WC# wireless control dimming	C custom
	Minimum 4ft; please consult factory Not available with 347V.	Requires 120V or 277V	(5) Please consult factory Specify quantity. Requires 8" blank See integrated controls guide for more details.	Please specify

● **SPECIFICATIONS**

CONSTRUCTION

Housing	Extruded aluminum (0.075" nominal) Up to 70% recycled content
End Cap	Cast aluminum
Interior Brackets	Die formed sheet steel (20 gauge)
Reflectors	White powder coated sheet steel (22 gauge)
Louvers	Die formed semi-specular aluminum (22 gauge)
Lenses	Extruded acrylic (0.070" nominal)

● **ELECTRICAL**

Lutron driver*	LDE1 - EcoSystem H-Series (1%) LDE5 - EcoSystem 5-Series (5%) LTE - Hi-Lume® A-series 2Wires Forward Phase (1%) <small>*Consult factory</small>
Other drivers	DALI - Digital Addressable Lighting Interface DMX - Digital Multiplex LV - line voltage - Advance Mark 10 Xitanium SR - For wireless sensor POE (Power over Ethernet) - Low Voltage Lighting System.
Emergency	Integral emergency battery pack or emergency circuit optional.
Input Voltage	120V, 277V, 347V, UNV.

i Incorporating these components may have limitations or affect the length of the luminaire. Please contact factory for more details.

● **LED SYSTEM**

CRI	Minimum 80 or 90 color rendering index.
CCT	Choice of 2700K, 3000K, 3500K and 4000K color temperature with a great color consistency (within 3-step MacAdam ellipse). Both within fixture and fixture to fixture.
LED life	Minimum 50,000h with 85% of lumen maintenance in 25°C ambient temperature, in compliance with IES LM-80 testing measurements.
Thermal Management	Aluminum housing acting as the heat sink to maximize life.
Environment	Dry and damp rated in operating ambient temperatures of 0-40°C (32-104F).
Louver LED	Individual for LED cluster in each louver cell.

● **OPTICS**

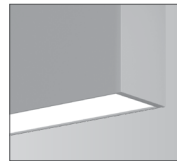

SO spotless lens



L Louver



0.25G Glo lens

SPOTLESS LENS

Frosted acrylic snap-in micro lens.

PARABOLIC LOUVERS

Die formed semi-specular aluminum (22 gauge).

GLO LENS

0.25" frosted acrylic drop lens. Patented design.

● **SYSTEM (S#)**

BEAM2 SQUARE linear systems, with the use of a strong profile, allow for a nearly hair thin connection system of continuous runs. Lengths of 4', 8', 12' as well as custom lengths are available. Runs of BEAM2 SQUARE that are greater than 12' in length are designated as systems (S#). This means that the run is comprised of a combination of 4', 8' and/or 12' sections to be assembled on site using our joining system. For more information on systems and joining, please refer to the BEAM2 installation sheets available for download at www.axislighting.com.

● **WARRANTY**

Axis Lighting will warrant defective LEDs, boards, and drivers for 5 years from date of purchase. Warranty is valid if luminaire is installed and used according to specifications. If defective, Axis will send replacement boards or drivers at no cost along with detailed replacement instructions and instructions on how to return defective components to Axis.

● **InstaJoiner**

TWIN BEAM2 SurroundLite luminaires feature InstaJoiner, a unique, patent-pending joining system developed by Axis offering fast, single-screw tightening.

NOTE: Mount each system segment individually.

Do not assemble system prior to mounting

i Allow a minimum of 6" between end of long runs and wall.

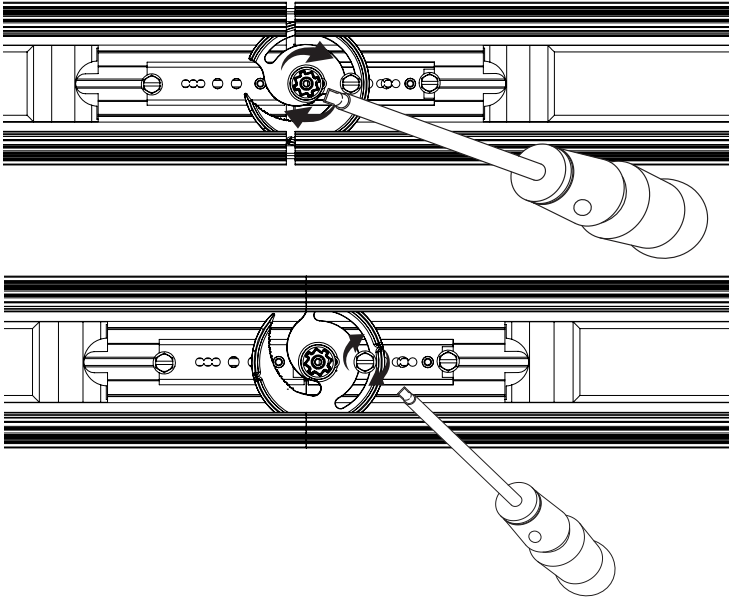

● **SECTION VIEWS**

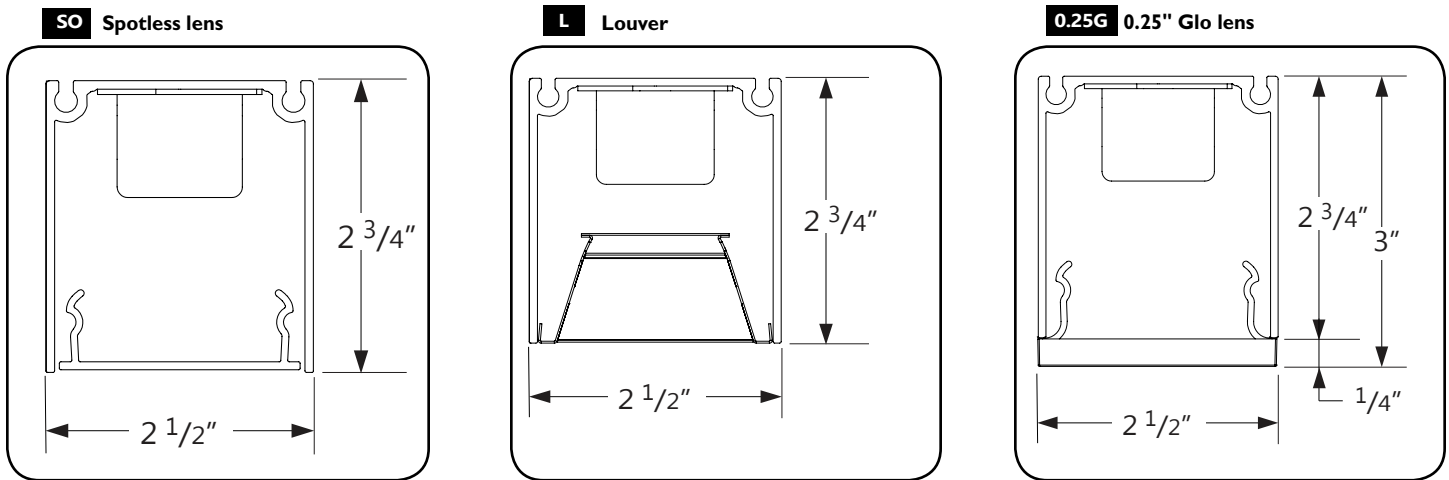

● MOUNTING DETAILS

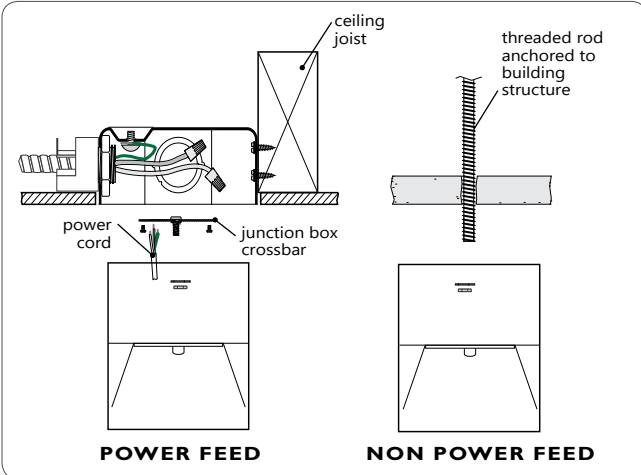

S SURFACE MOUNT DRYWALL CEILING

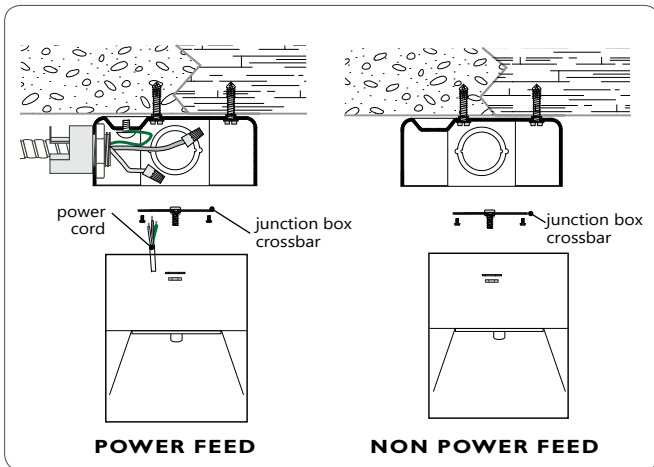

SC SURFACE MOUNT SOLID CEILING

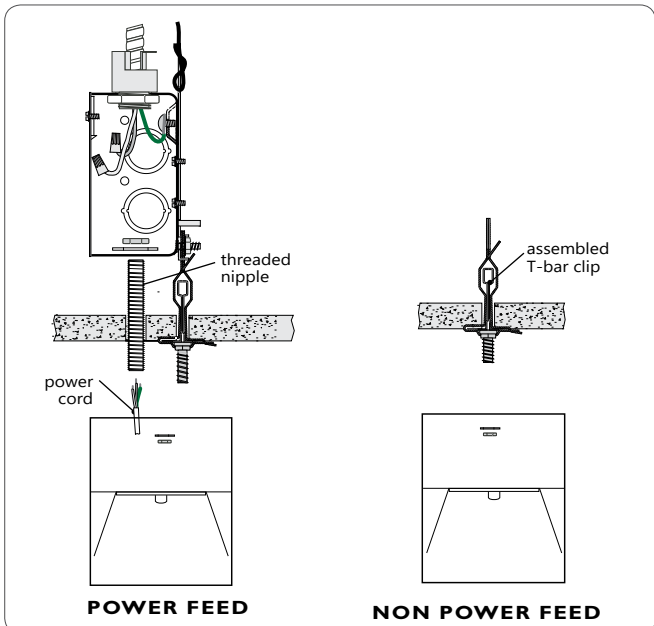

SB9 SB15 SBS SURFACE MOUNT T-BAR CEILING

● DMLED MODULE

Blank Extruded aluminum (0.075" nominal)
LED Module 2" diameter
Quantity For every 4' section, there may be up to a maximum of 4 x DMLED module.
Spacing Each DMLED module is placed centered on a blank section 6" in length.

For a series of modules within a given section length, they will be spaced evenly on a longer blank section. Custom spacing may be available on special request.

Tilt 15° each side.

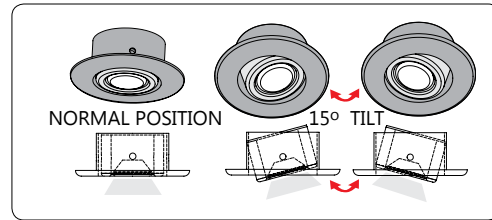

Between sections

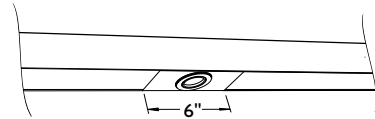

At luminaire ends

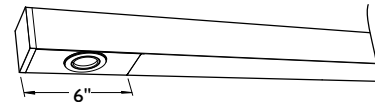

Several in a long blank section

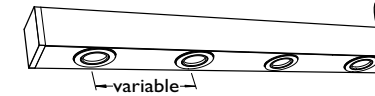

Beam Angle	30 nominal degrees
Input Watts	3W
Nominal Lumens	126 lumens
Efficacy	42 lumens per watt
Color Rendering Index (CRI)	80
Life	25,000 hours at L ₇₀
Correlated color temperature (CCT)	3000K

i More options are available upon request. Please consult factory.

* See photometric report.

● OTHER MOUNTING OPTIONS

BEAM2 SQUARE is also available with pendant and wall mounted options.

i Specification sheets and installation sheets for all mounting for BEAM luminaires are available for download at www.axislighting.com

PHOTOMETRIC DATA

SO - Spotless lens
400 lm/ft



PHOTOMETRIC CURVE

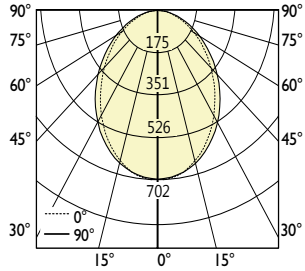

Lumen/ft: 400 lm/ft
Total Lumens: 1600 lm (for 4ft)
Input Watts: 16.1 W
Efficacy: 99 lm/W

IES FILE: B2SQDLED-0-400-80-35-SO-4.IES

TESTED ACCORDING TO IES LM-79-2008

80 CRI shown. To calculate watts and efficacy at 90 CRI, apply a multiplier of 0.8.

CANDELA DISTRIBUTION

Vertical Angle	Horizontal Angles				
	0	22.5	45	67.5	90
0	700	700	700	700	700
5	698	693	694	695	694
15	646	646	650	655	656
25	559	561	572	582	585
35	451	456	470	484	489
45	342	347	362	377	382
55	241	247	259	272	275
65	154	157	166	175	177
75	80	81	86	91	91
85	20	21	23	25	25
90	1	1	2	2	3

ZONAL LUMENS

Zone	Lumens
0	
0-10	66
10-20	183
20-30	263
30-40	294
40-50	280
50-60	232
60-70	165
70-80	92
80-90	27
90	

LUMINANCE DATA (cd/m²)

Vertical Angle	Horizontal Angles		
	0	45	90
45	2955	3621	6587
55	2097	2673	5720
65	1387	1832	4804
75	773	1056	3748
85	221	324	2261

SO - Spotless lens
500 lm/ft



PHOTOMETRIC CURVE

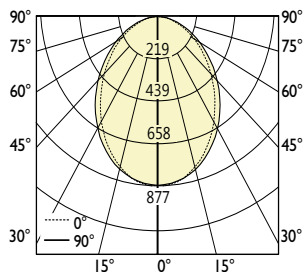

Lumen/ft: 500 lm/ft
Total Lumens: 2003 lm (for 4ft)
Input Watts: 20.2 W
Efficacy: 99 lm/W

IES FILE: B2SQDLED-0-500-80-35-SO-4.IES

TESTED ACCORDING TO IES LM-79-2008

80 CRI shown. To calculate watts and efficacy at 90 CRI, apply a multiplier of 0.8.

CANDELA DISTRIBUTION

Vertical Angle	Horizontal Angles				
	0	22.5	45	67.5	90
0	874	874	874	874	874
5	873	867	867	868	868
15	808	808	812	819	820
25	699	702	715	727	731
35	564	571	588	605	611
45	427	434	453	472	477
55	301	309	324	340	344
65	192	197	208	219	221
75	100	102	108	114	114
85	26	26	29	31	32
90	1	1	2	3	4

ZONAL LUMENS

Zone	Lumens
0	
0-10	82
10-20	229
20-30	329
30-40	368
40-50	350
50-60	290
60-70	206
70-80	115
80-90	34
90	

LUMINANCE DATA (cd/m²)

Vertical Angle	Horizontal Angles		
	0	45	90
45	3693	4526	8234
55	2621	3341	7150
65	1733	2289	6005
75	966	1320	4685
85	276	404	2826

● PHOTOMETRIC DATA

SO - Spotless lens
750 lm/ft



PHOTOMETRIC CURVE

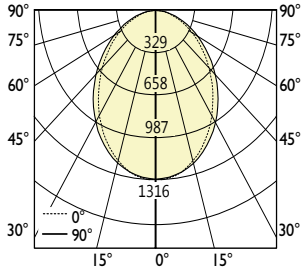

Lumen/ft: 750 lm/ft
Total Lumens: 3005 lm (for 4ft)
Input Watts: 30.3 W
Efficacy: 99 lm/W

IES FILE: B2SQDLED-0-750-80-35-SO-4.IES

TESTED ACCORDING TO IES LM-79-2008

80 CRI shown. To calculate watts and efficacy at 90 CRI, apply a multiplier of 0.8.

CANDELA DISTRIBUTION

Vertical Angle	Horizontal Angles				
	0	22.5	45	67.5	90
0	1312	1312	1312	1312	1312
5	1309	1300	1301	1302	1302
15	1212	1212	1219	1229	1230
25	1048	1053	1072	1090	1096
35	846	856	882	908	917
45	641	652	680	708	716
55	452	463	486	510	516
65	288	295	312	328	331
75	150	153	162	171	171
85	38	40	43	46	47
90	2	2	3	4	6

ZONAL LUMENS

Zone	Lumens
0	
0-10	123
10-20	343
20-30	493
30-40	552
40-50	525
50-60	435
60-70	310
70-80	173
80-90	51
90	

LUMINANCE DATA (cd/m²)

Vertical Angle	Horizontal Angles		
	0	45	90
45	5540	6789	12351
55	3932	5012	10726
65	2600	3434	9008
75	1449	1980	7028
85	415	607	4240

SO - Spotless lens
1000 lm/ft



PHOTOMETRIC CURVE

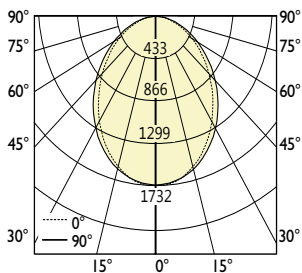

Lumen/ft: 1000 lm/ft
Total Lumens: 3955 lm (for 4ft)
Input Watts: 39.97 W
Efficacy: 99 lm/W

IES FILE: B2SQDLED-0-1000-80-35-SO-4.IES

TESTED ACCORDING TO IES LM-79-2008

80 CRI shown. To calculate watts and efficacy at 90 CRI, apply a multiplier of 0.8.

CANDELA DISTRIBUTION

Vertical Angle	Horizontal Angles				
	0	22.5	45	67.5	90
0	1726	1726	1726	1726	1726
5	1723	1711	1712	1714	1713
15	1595	1596	1604	1617	1620
25	1380	1386	1411	1435	1443
35	1114	1127	1160	1195	1207
45	844	858	894	932	942
55	595	609	639	671	679
65	379	388	410	432	436
75	197	201	213	226	225
85	51	52	56	61	62
90	3	3	4	6	7

ZONAL LUMENS

Zone	Lumens
0	
0-10	162
10-20	452
20-30	649
30-40	726
40-50	691
50-60	573
60-70	408
70-80	227
80-90	67
90	

LUMINANCE DATA (cd/m²)

Vertical Angle	Horizontal Angles		
	0	45	90
45	7292	8937	16258
55	5175	6598	14118
65	3423	4520	11858
75	1907	2606	9251
85	546	799	5581

● **PHOTOMETRIC DATA**

L - Louver



1000 lm/ft

PHOTOMETRIC CURVE

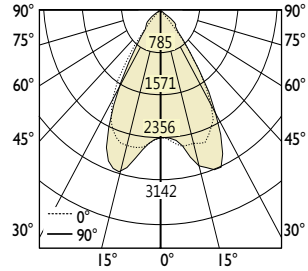

Lumen/ft: 1000 lm/ft
Total Lumens: 3854 lm (for 4ft)
Input Watts: 39.6 W
Efficacy: 97 lm/W

IES FILE: B2SQDLED-0-1000-80-35-L-4.IES

TESTED ACCORDING TO IES LM-79-2008

80 CRI shown. To calculate watts and efficacy at 90 CRI, apply a multiplier of 0.8.

CANDELA DISTRIBUTION

Vertical Angle	Horizontal Angles				
	0	22.5	45	67.5	90
0	2297	2297	2297	2297	2297
5	2356	2348	2337	2321	2312
15	2483	2504	2693	2915	2904
25	2322	2513	3107	3055	2851
35	1290	1752	2342	1633	1320
45	194	307	658	478	428
55	32	48	76	175	250
65	6	8	13	17	20
75	2	2	3	5	5
85	0	1	1	1	1
90	0	0	0	0	0

ZONAL LUMENS

Zone	Lumens
0	
0-10	228
10-20	768
20-30	1260
30-40	1073
40-50	397
50-60	106
60-70	19
70-80	4
80-90	1
90	

LUMINANCE DATA (cd/m²)

Vertical Angle	Horizontal Angles		
	0	45	90
45	4597	15642	10171
55	949	2223	7334
65	219	521	807
75	110	208	312
85	77	154	212