

Project Name: _____ Type: _____ Quantity: _____

INTENDED USE

The specification-grade architectural submersible pond and fountain underwater LED light is the ideal solution for underwater applications where quality LED lighting is desired.

FEATURES

- Construction:** Brass
- Lens:** Heat Resistant, Tempered Glass
- Lamp:** Replaceable Sealed-Beam LED Lamp
- Beam Spread:** 120°
- Color Temperature:** 6400K
- Wattage:** 9W
- Lumens:** 900 lm
- Voltage:** 12V
- Life:** 50,000 Hours
- Listings:** ETL Approved for Underwater, IP68 rated
- Warranty:** 5 Years Carefree for Parts & Components (Labor Not Included)

Pre-Wired with UL Listed 21' 16/3 Underwater Cable

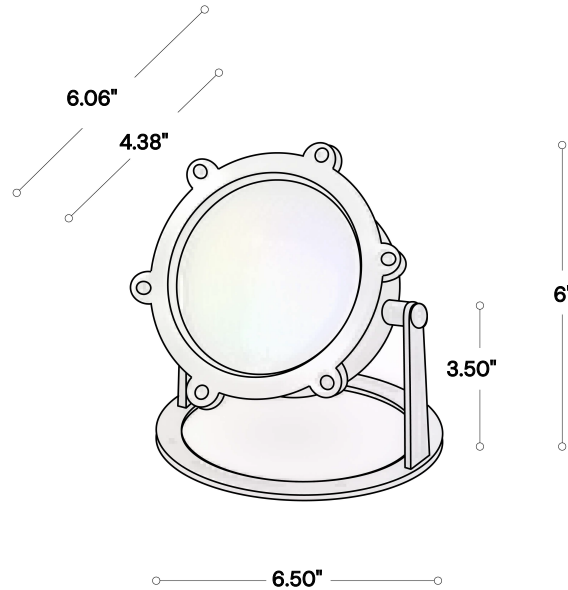

ORDERING INFORMATION Example: [17003](#)

Model
17003

Alcon 17003 Architectural Submersible Pond and Fountain Underwater LED Light