

### FIXTURE SPECIFICATIONS

#### INTENDED USE

The specification grade Hobart Architectural LED High and Low Bay Pendant provides high CRI increasing the light quality of a space and improving visibility, thus reducing the chance of accidents. The Hobart is an ideal option for commercial applications and interior spaces looking for bright and efficient lighting.

#### FEATURES

- Construction: Spun Matte Anodized .063 Aluminum Housing
- Mounting: 6FT Adjustable Aircraft Cable/Power Cord
- Canopy: Mounts to Standard J-Boxes
- Lens: Frosted 3/16" Tempered, Soda Lime Glass with 2" Vent
- Gasket: Rubber
- Driver: Constant Current
- Voltage: 120V/277V
- Wattage: 56W
- Lumens: 5850 lms
- Dimming: 5-Wire 0-10V Dimming 100%-10%
- CRI: 87
- Efficacy: 66.68
- Listings: cUL Listed for Dry Location Only



Alcon 15203 Architectural LED High and Low Bay Pendant Direct Down Light Fixture

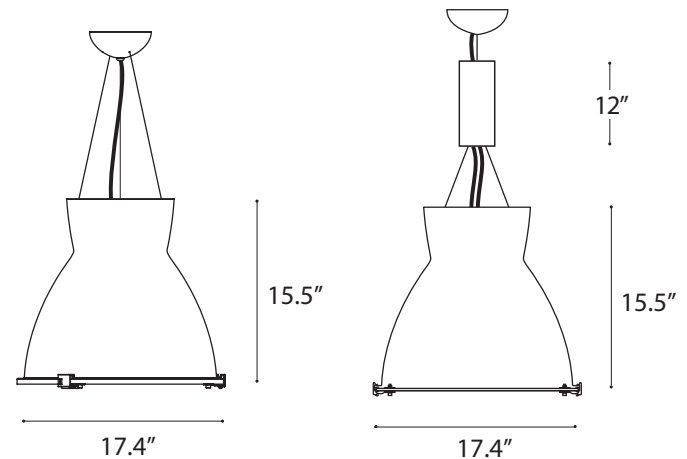

### ORDERING INFORMATION Example: (15203-AN-30K)

Model	Finish	Color Temp	Options
15203	AN	Anodized	EM <sup>1</sup> Emergency Backup Battery 10 watts   3558 lumens
	WH	White	
	BK	Black	

<sup>1</sup>Emergency Operation for 90 Minutes