

## FIXTURE SPECIFICATIONS

### INTENDED USE

The specification grade Alcon Lighting 15235 Melbourne Round Cone LED High Bay Commercial Lighting Pendant is the ideal solution for warehouse, gymnasium, or other mid to high-ceiling applications where high output LED lighting is desired.

### FEATURES

- Construction: Die-cast aluminum housing and heat sink
- Shade: Handblown glass shade
- Canopy: Canopy mounts to standard J-boxes
- Cord: 6 ft. power cord is standard
- CRI: 90+
- Wattage: 21 watts
- Lumens: 2,125 delivered lumens
- Driver: 0-10V 5-wire 1% dimming
- Input Voltage: 120/277V, 50/60Hz
- Emergency Lighting: Optional remote 10-watt emergency LED driver for lighting up to 90 minutes in event of power failure
- Listings: cUL listed for damp locations
- Warranty: 5 years carefree for parts & components (labor not included)

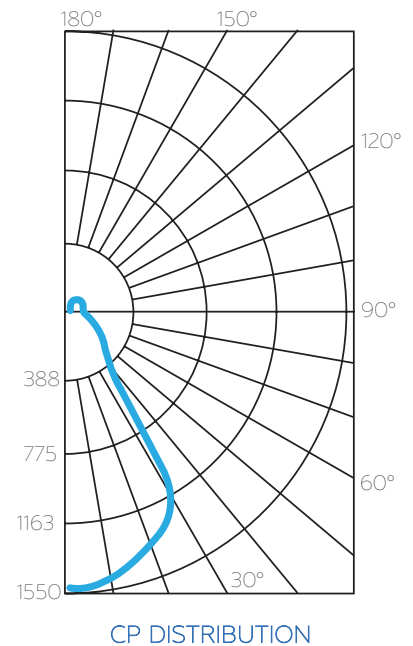
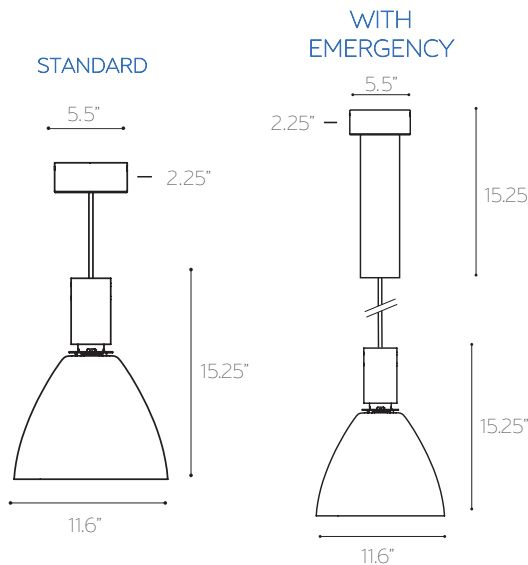

## ORDERING INFORMATION Example: (15235-SL-WH-30K)

Model	Housing   Cord   Canopy Color	Glass Shade Color	Color Temperature	Options
15235	SL Silver	WH White	30K 3000K	EM7 Remote 10W Emergency Back-Up Battery
	WH White	OR Orange	35K 3500K	ACX Additional Pendant Length (Consult Factory)
		LA Lavender	40K 4000K	
		OB Ocean Blue		

Alcon 15235 Melbourne Round High Bay Commercial Lighting Pendant