

FIXTURE SPECIFICATIONS

INTENDED USE

The specification-grade architectural submersible pond and fountain underwater RGBW LED light is the ideal solution for underwater applications where quality LED lighting is desired.

FEATURES

Construction: Marine Grade 316 Stainless Steel

Lens: Heat Resistant, Tempered Glass

Lamp: Replaceable Sealed-Beam LED Lamp

Beam Spread: 120°

Color Temperature: Adjustable light color mixing, Full color range change, RGBW via Remote Control (within 100ft)

Wattage: 9 Watt

Voltage: 12V

Life: 50,000 Hours

Listings: ETL Approved for Underwater Applications

Warranty: 5 Years Carefree for Parts & Components (Labor Not Included)

Pre-Wired with UL Listed 21' 16/3 Underwater Cable

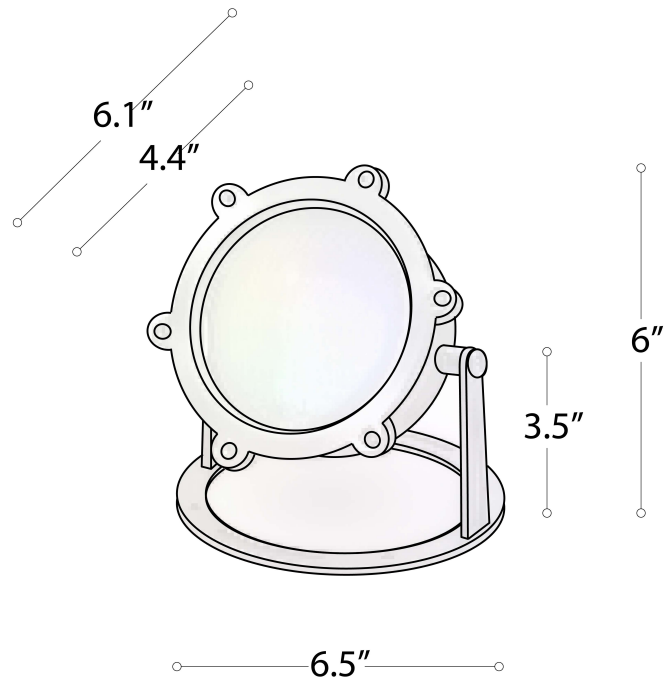

Alcon 17003 Architectural Submersible Pond and Fountain Underwater RGBW Light

ORDERING INFORMATION Example: (17003)

Model

17003