

### FIXTURE SPECIFICATIONS

#### INTENDED USE

Our in-ground, landscape LED well path light includes a prismatic cover to maximize light output with a tempered diffuser which protects the light from environmental hazard. The light is designed for below-grade applications in most locations, soil and concrete.

#### ADDITIONAL FEATURES

**D** 6.75" x **W** 6.75" x **H** 14.02"

**Construction:** Cast Aluminum w/ PVC Sleeve **Installation:** Rated for In-Ground Soil and Concrete Applications **Lens:** Prismatic Clear, Heat Resistant, Tempered Diffuser

**RGBW Controller:** Bluetooth via Smart Life - Smart Living mobile app (available for iOS and Android devices) **CRI:** 80+

**Life:** 35,000 Hours

**Listing:** ETL Approved for Wet Location

**Warranty:** 1 year

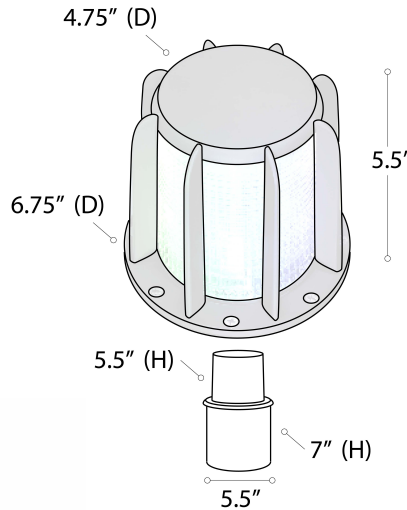

Alcon 9099 7-Inch In-Ground LED Well Light



### ORDERING INFORMATION Example: (9099-RGBW-BK)

Model	Lamp Type	Color Temp	Finish
9099	RGBW   15W   1300 lms   120° Beam Spread   120V	(Blank) RGB + W (27-64K)	BK Black VG Verde Green
W-25	White   12.5W   1200 lms   25° Beam Spread   120-277V	27K 2700K	
W-40	White   12.5W   1200 lms   40° Beam Spread   120-277V	30K 3000K 40K 4000K 50K 5000K	