

## INSTALLATION INSTRUCTIONS

### LED FIXTURE INFORMATION & WARNINGS

- Read all warnings and instructions to reduce the risk of death, personal injury or property damage from fire, electric shock, falling parts, cuts abrasions and other hazards
- Make sure that you have all necessary parts by checking the parts list. If any part is missing or damaged, please contact Alcon Lighting Customer Service at (877) 733-5236.
- This product must be installed in accordance with the applicable local & national electrical codes.
- Do not substitute any parts, leave parts out, or use any parts that are worn or broken. All parts must be used as indicated in these instructions.
- Please handle the LED light with care when unpacking. Do not apply pressure to the LED's, do not open any factory sealed compartments, and do not touch the LEDs with your hands.
- Do not remove or replace the driver that is provided with the fixture.
- Excess cable should be neatly looped and tucked into the canopy. **DO NOT CUT WIRES** attached to the fixture under any circumstance. Cutting wires will **VOID** your warranty.
- Please remove the canopy from the box prior to removing the fixture body. Failure to do so can potentially lead to cables getting tangled.
- Disconnect power prior to installation or servicing of fixture, fixture is designed to be installed to a junction box (not provided).

**Fixture Diagram:** All fixtures mount the same way (including multi-tier fixtures)



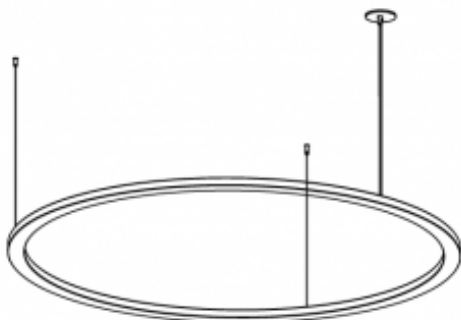

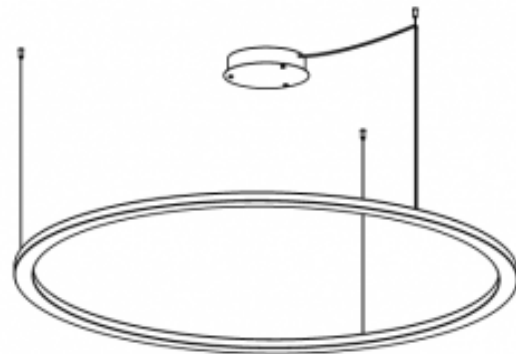

Standard Remote



Remote install with canopy



### Parts List

- (A) Mounting Bracket   (B) Plastic Anchors   (C) Anchor Screws  
        
 (D) Outlet Screws   (E) Wire Connectors   (F) Canopy Screws  
      

### Parts Packed with Fixture

- (B) Plastic Anchors x 4   (C) Anchor Screws x 4   (D) Outlet Screws x 3   (E) Wire Connectors x 3

### Tools You May Need



## STANDARD REMOTE

**WARNING:** disconnect main power at the source prior to installation! Only qualified electricians should install Alcon Lighting products.

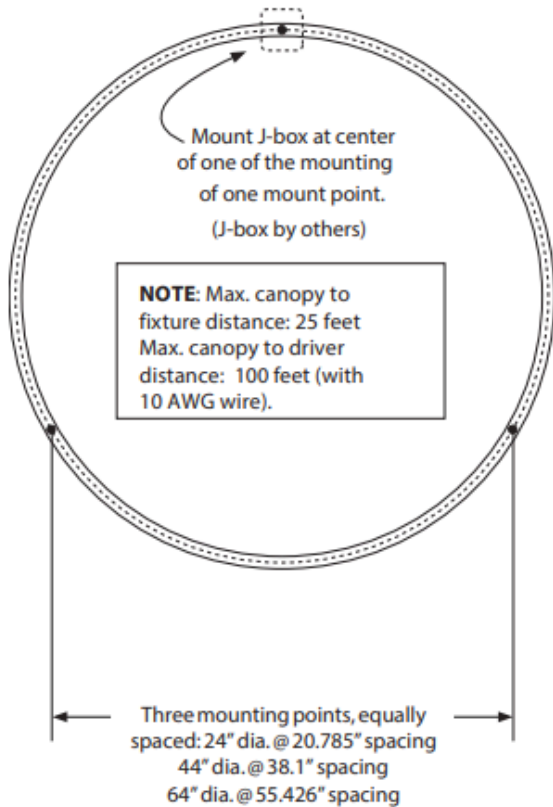
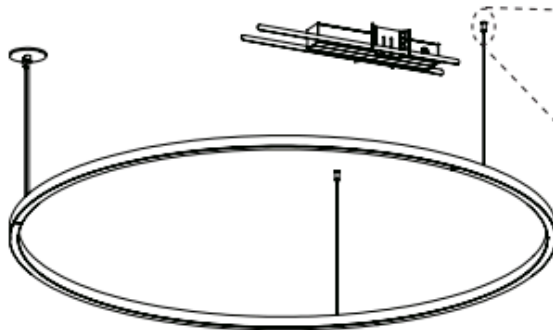

### Circline wiring:

Red to 24VDC positive  
Blue to 24VDC negative

### Dimming:

Purple and Gray wires from driver to 0-10V dimmer, cap if not used.

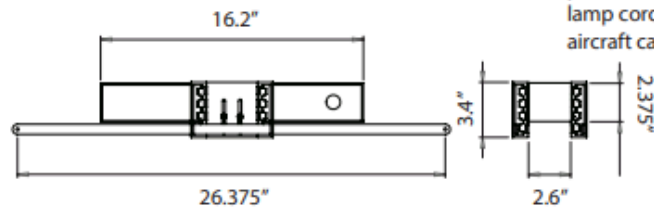
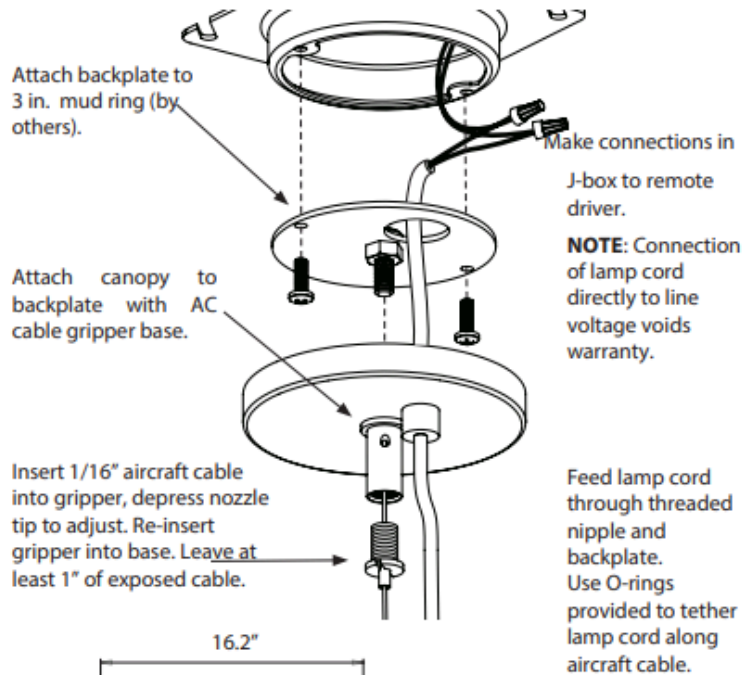
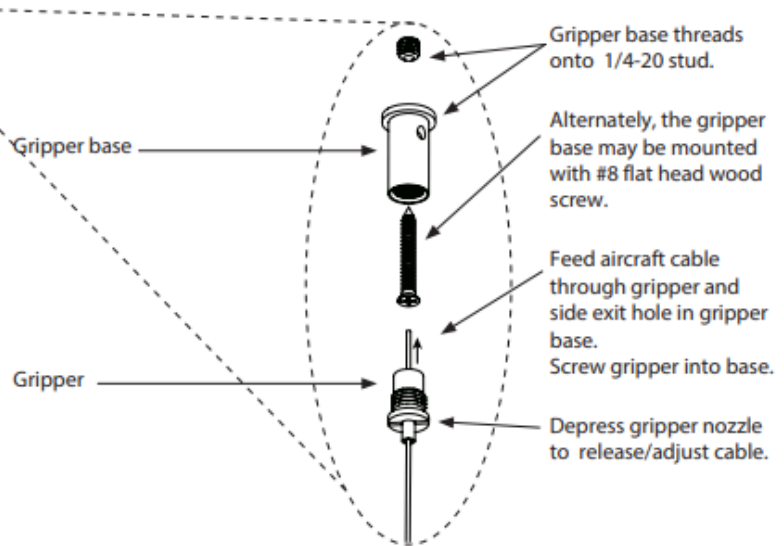

Remote driver includes bar hangers to mount above suspended ceilings. Drivers must remain accessible after installation.

Driver housing must not be mounted any closer than 4 inches apart. Bar hangers and brackets may be removed for direct mount to structure with screws. Connect J-box to driver housing with conduit (by others).

## REMOTE WITH CANOPY

**WARNING:** disconnect main power at the source prior to installation! *Only qualified electricians should install Alcon Lighting products.*

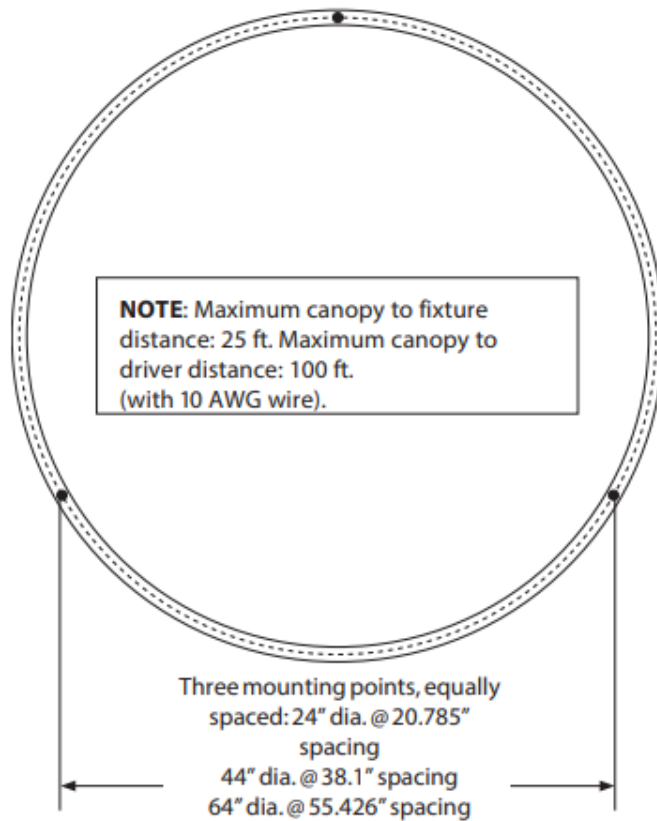
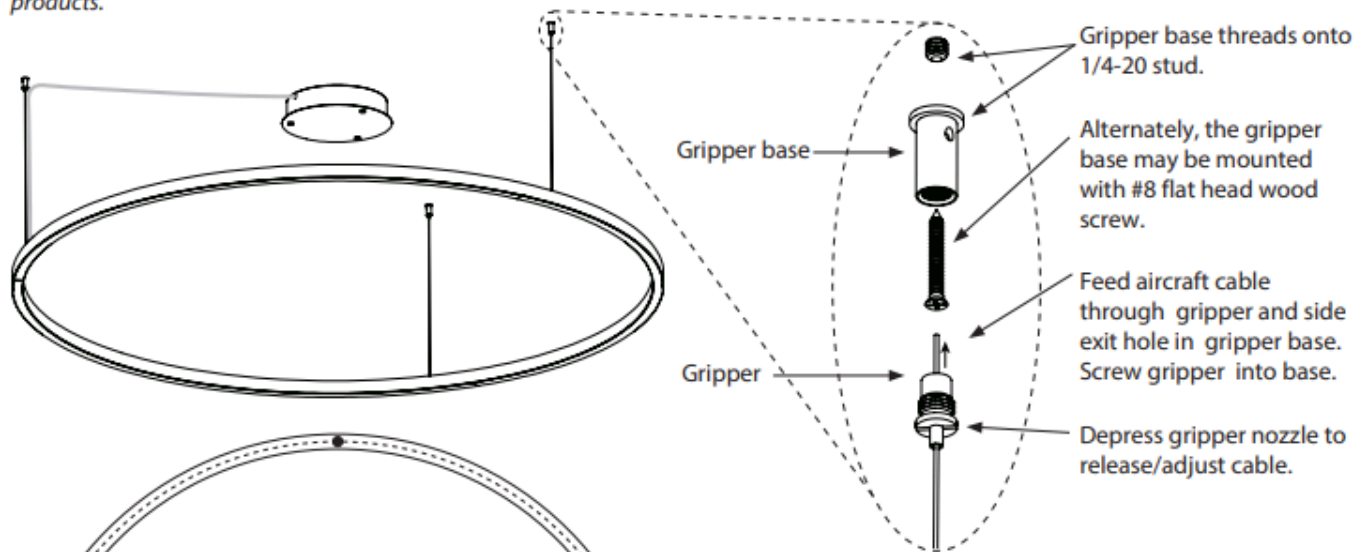

### Circline wiring:

Red to 24VDC positive  
Blue to 24VDC negative

### Dimming:

Purple and Gray wires from driver to 0-10V dimmer, cap if not used.

Mount driver housing to octagonal box or mud ring. Wire up drivers to line voltage on primary side.

Feed lamp cord through side of housing, secure with screw-down strain relief. Wire up according to wiring diagram, left.

